

UGL REGIONAL LINX



CRN GM 001 Standards & Codes System Manual
CRN-MAN-AMS-713026361-365

LINKING
COMMUNITIES.

CONNECTING
CUSTOMERS.



Table of Contents

1	Document Control.....	iii
2	Introduction.....	1
3	Scope and application	1
4	References	1
4.1	Australian and International Standards	1
4.2	UGLRL Documents.....	1
4.3	Other references.....	2
4.4	Common abbreviations and definitions	2
5	Standards and codes policy, objectives and requirement.....	3
5.1	Policy	3
5.2	Objectives	3
5.3	Requirement for engineering standards	4
6	The architecture.....	4
6.1	Architecture principles	4
6.2	Standards & Codes and Related Documents.....	5
6.3	Scope of Standards & Codes Coverage.....	5
6.4	Breakdown Structure and Numbering System	6
6.4.1	Structure of Standards.....	6
6.4.2	Numbering System	7
6.4.3	General Standards.....	8
6.4.4	Civil, Signal, Electrical, Plant and Rolling Stock Standards & Codes.....	8
7	Application of engineering standards	8
7.1	Relevant personnel.....	8
7.2	Currency and understanding	9
7.3	Standards & Codes interpretation and precedence	9
7.4	Principal Engineers and Standards & Codes management	9
7.5	Competency Requirements	9
7.6	Engineering licensing and authority.....	11
7.7	Verification, validation, certification and / or approval	13
7.8	Compliance and audit	13
7.9	Management of non-compliance	14
7.10	Change and configuration management	14
7.11	Application of risk management to engineering standards.....	14
7.12	Concessions and waivers	14
7.13	Communications	15
7.14	Records of Standards & Codes application.....	15
8	Standards & Codes interfaces.....	15
8.1	CRN infrastructure asset management	15



8.2	Infrastructure maintenance, works and infrastructure operations	16
8.3	Network, train and on-track equipment operations.....	16
8.4	Safety and environmental management.....	16
8.5	7.5 Human resources and training	16
9	Standards & Codes improvement framework	17
9.1	Standards & Codes review and change	17
9.2	Identifying Standards & Codes issues and opportunities for improvement.....	17

1 Document Control

Function	Position	Name	Date
Originator	Pervious Incumbent Service provider reviewed	Jagath Peiris	25.11.2021
Approver	Asset & Engineering Manager	Lucio Favotto	30.11.2021

Revision	Issue Date	Revision Description
1.3	08.2020	Previous CRN provider issue
2.0	25.11.2021	First UGLRL Issue

2 Introduction

This manual explains the context of and provides an introduction to the Country Regional Network (CRN) Standards & Codes, including those published and managed by TfNSW for exclusive CRN use and Operational Maintenance Standards published and managed by UGLRL (Refer to CRN-FRA-RLS-459032646-253 - General Engineering and Operation Safety Systems and CRN-E-P004 for the initial list of Standards & Codes applicable to the CRN O&M contract and separation of management responsibilities between TfNSW and UGLRL).

3 Scope and application

The manual outlines the architecture for the suite of Standards & Codes which are used for the design, installation, maintenance, and operation of the CRN.

The suite of Standards & Codes is applicable to;

- infrastructure assets designed for and installed on the CRN, including associated assets, subject to the UGLRL CRN Management Contract and its associated rail safety accreditation; and
- rolling stock, plant and equipment assets utilised on or for the CRN.

Infrastructure assets of the CRN are made up of;

- civil infrastructure, consisting of track, structures, buildings and right of way assets;
- signal, communications, and train control assets, including asset systems hardware and software; and
- electrical infrastructure.

Rolling stock, plant and equipment assets, relevant to the suite of standards and codes are made up of;

- rolling stock and on-track plant and equipment that may operate on CRN track; and
- other plant and equipment that may be utilised for the design, fabrication, construction, installation, maintenance, disposal or operation of CRN infrastructure assets.

The suite of Standards & Codes covers only the engineering requirements for the above assets. In addition to the engineering requirements, UGLRL will need to comply with other regulatory and contract requirements for the overall protection, operation, and safe use of the assets.

4 References

4.1 Australian and International Standards

- International Engineering Safety Management Good Practice Handbook Volume 1 - Issue 1.1 September 2013 and Volume 2 - Issue 1.2 Jan 2017, Technical Programme Delivery Group, UK

4.2 UGLRL Documents

- CRN-PLN-RLS-459032646-216 - Management Responsibilities, Authorities & Accountabilities Procedure
- CRN-POL-AMS-713026361-114 - Asset Management Policy
- CRN-MPN-RLS-713026361-103 - Asset Management Framework

- CRN-PLN-AMS-713026361-304 - Configuration Management Plan
- CRN-PLN-AMS-1737869751-32 - Terms of Reference - Configuration Control Board
- CRN-FRA-RLS-459032646-253 - General Engineering and Operation Safety Systems
- CRN-PRC-RLS-459032646-177 - Management of Change Procedure
- CRN-MPN-QMS-823503868-10 - Quality Assurance Management Plan
- CRN-PLN-AMS-713026361-180 O&M Services Technical Competency, Authority and Review Plan (TCARP)
- CRN-E-P004 Changes to Engineering Standards

4.3 Other references

- Rail Safety National Law (as in force in NSW and the ACT)
- Rail Safety National Law National Regulations (as in force in NSW and the ACT)
- Country Regional Network Operations and Maintenance Deed between UGLRL Pty Ltd and TfNSW
- Country Regional Network O & M Deed Scope of Works Appendices A & B as amended by CRN-E-P004

4.4 Common abbreviations and definitions

Table 1: Common abbreviations and definitions

UGL	Parent Company of UGLRL
CRN	Country Regional Network
UGLRL	UGL Regional Linx, the subsidiary company of UGL that is solely responsible for the management of the CRN
Standards & Codes (S&C)	A collective term for the entire suite of available engineering documents for the design, construction, inspection and maintenance of the railway, which entail Standards, Manuals, Specifications and Technical Notes/Technical Directions. Engineering Standards & Codes and Operational Maintenance Standards together make up this suite.
Engineering Standards & Codes (ESC)	These are documents that set technical requirements for design, construction, or maintenance of assets to enable them meet intended purposes to expected levels. These documents are branded TfNSW and are published and managed by TfNSW.
Operational Maintenance Standards (OMS)	These are derived documents that prescribe the methods, tools procedures and activities to be performed on assets when operating and maintaining them during use to achieve intended asset outcomes and design life. These documents are branded UGLRL CRN and are published and managed by UGLRL.
Standard	A type of document addressed primarily to Designers and Asset Managers, which establish the functional and design requirements, approved configuration, acceptance standards. (These are usually published and managed by TfNSW)

Manual	A type of document addressed primarily to persons undertaking field activities, which detail the technical procedures for the installation, inspection and maintenance of assets, including the competency and management requirements as well as maintenance limits and responses
Specification	A type of document addressed primarily to persons undertaking procurement of products and materials, which detail acceptance requirements or processes during the procurement or as a model for specifications for works. (These are usually published and managed by TfNSW)
Licence	An authority to make engineering decisions related to CRN infrastructure in accordance with the applicable Standards & Codes.
RIW Program and System	The Rail Industry Worker Program (RIW) is a national competency management framework for rail workers across Australia. The RIW System is the core solution to the RIW Program and provides a secure platform that houses all information.
Technical Competency, Authority and Review Plan (TCARP)	The TCARP is a standard tool in the UGL Management System used to identify and describe the approach to competency management and assignment of engineering authority to personnel engaged in the delivery of engineering services by a UGL controlled entity such as UGL Regional Linx.
Technical Note/ Technical Direction	A type of document produced for a specific defined audience to provide a controlled means of communicating technical issues to those undertaking activities on the relevant infrastructure. They may also provide interim changes to standards, manuals, or specification, and typically have a defined life.

5 Standards and codes policy, objectives and requirement

5.1 Policy

The Standards & Codes are developed to meet the applicable requirements of the following UGLRL CRN policies:

- Asset Management
- Rail Safety
- WHS
- Environment
- Quality

5.2 Objectives

The objectives for Standards & Codes management are to;

- provide a Standards & Codes framework for delivery of the intent of UGLRL policies;
- meet the requirements for Engineering Standards set defined in CRN-FRA-RLS-459032646-253 - General Engineering and Operation Safety Systems; and

- meet the objectives and requirements of the UGLRL Asset Management System, including the role of standards and codes in the applicable asset management model.

5.3 Requirement for engineering standards

The core requirement for engineering standards for the CRN is called up by Clause 19 of Schedule 1 of the Rail safety National Law National Regulation 2012:

“19 General engineering and operational systems safety requirements

(1) *A documented set of engineering standards and procedures, and operational systems, safety standards and procedures, to cover the following, and, if relevant, the interface between any 2 or more of them—*

(a) *rail infrastructure;*

(b) *rolling stock;*

(c) *operational systems.*

(2) *Details of the implementation and updating of the documents specified in subclause (1).*

(3) *Procedures for the control and verification of the design of structures, rolling stock, equipment, and systems, in accordance with the engineering standards and procedures, and operational systems safety standards specified in subclause (1).*

(4) *Systems, procedures and standards for the following in relation to rail infrastructure and rollingstock—*

(a) *engineering design;*

(b) *construction and installation;*

(c) *implementation and commissioning;*

(d) *monitoring and maintenance;*

(e) *system operation;*

(f) *modification;*

(g) *decommissioning or disposal.”*

The standards & codes documents principally cover the Clause 19 requirements above for “engineering standards and procedures”. Requirements for “operational systems and safety standards and procedures” are principally covered by other UGLRL documents.

6 The architecture

6.1 Architecture principles

The structure of the standards and codes documents has been developed with the following principles in mind:

- The structure of the standards considers the context of the CRN within the overall management of the NSW and interstate rail network.
- The structure and content of the standards considers the degree of transferability of rolling stock and infrastructure works supplier resources between different NSW network management areas.
- The structure and content of the standards considers the scope and scale of the CRN network.
- The structure of the standards documents maintains a degree of discipline breakdown commonality with other principal NSW infrastructure managers and network operators.

- The structure of the standards also maintains a degree of discipline breakdown commonality with the standards applicable to the CRN at the time of transfer of the CRN network to UGLRL.
- All standards documents are pre-fixed with “CRN” to distinguish them from the standards of the other principal NSW infrastructure managers and network operators. Engineering standards and codes that have been rebranded as TfNSW are numbered according to the TfNSW document numbering system. The pre-existing CRN document numbers have also been kept on those as separate identifiers.
- The hierarchy of nomenclature within the standards numbering system is:
 - Organisation (i.e. “CRN”)
 - Discipline (e.g. “C” for civil)
 - Type of Document (e.g. “S” for standard and “M” for manual)
 - Unique 3 digit number for a standards document within a discipline (e.g. “001” for the highest level document within a discipline)
 - g. “CRN CS 200” for the Civil Standard “Track System”

6.2 Standards & Codes and Related Documents

Standards & Codes documents generally comprise the following:

- Standards
- Manuals
- Specifications
- Associated documents, called up by the above, which may include forms, templates, data collections, standard drawings, type approved equipment lists, engineering waivers and concessions, and technical notes.

Note: *Within the engineering disciplines of the CRN, including civil, signalling and rolling stock, there are some variations as to how documents are classified as “Standards”, “Manuals” or “Specifications” due to historical industry practice within the discipline. Additionally, the word “standards” may be used to refer generically to all these types of documents. This variation is retained in the CRN Standards & Codes for consistency across disciplines within the NSW rail industry.*

6.3 Scope of Standards & Codes Coverage

The scope of Standards & Codes coverage is specified in CRN Engineering Manual CRN GM 003.

6.4 Breakdown Structure and Numbering System

6.4.1 Structure of Standards

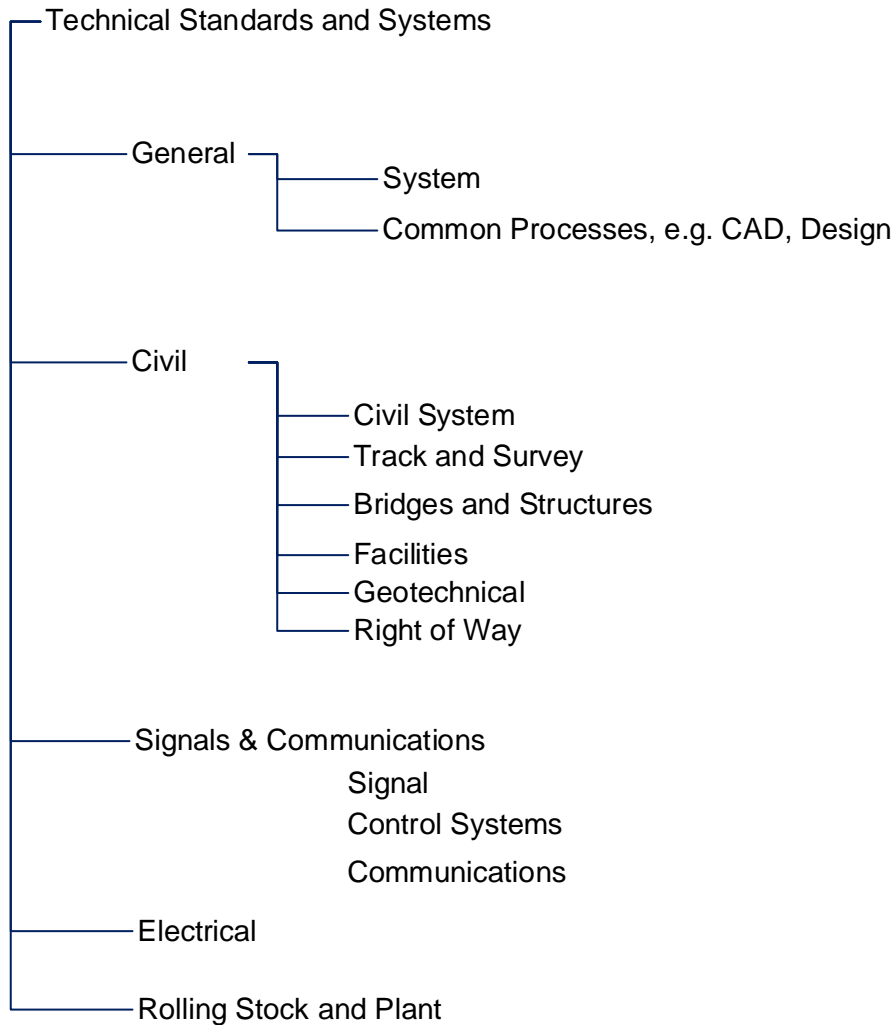
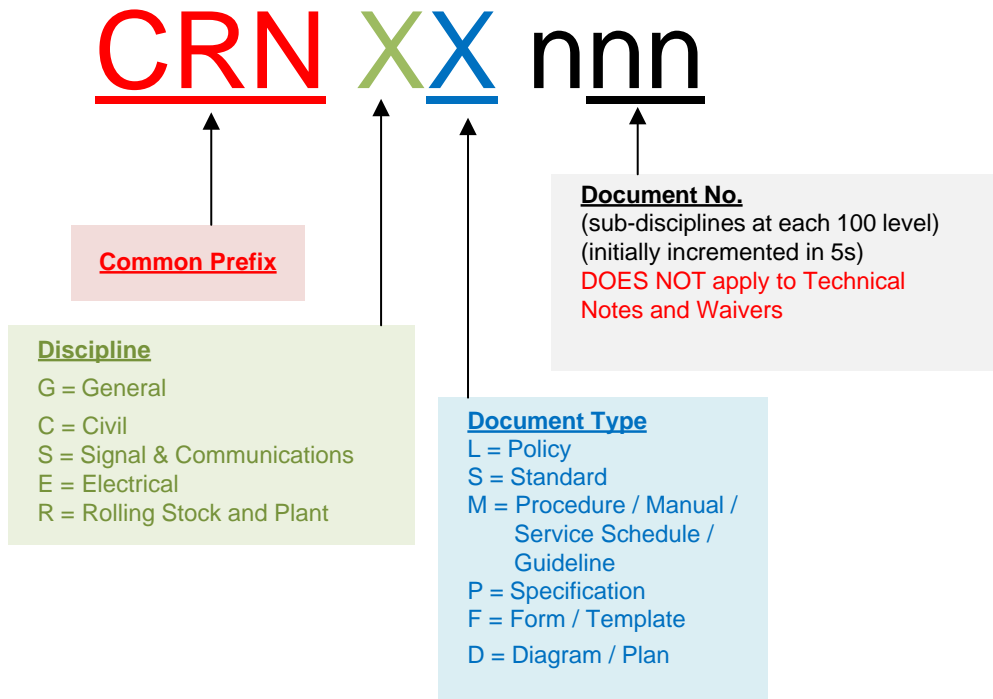

Figure 1: Breakdown Structure of Standards

6.4.2 Numbering System

Documents are numbered as shown below. Every stand alone document within a different type of document shall have a unique document number.



General Document numbering convention (Note: Doc. Types may vary between disciplines.)

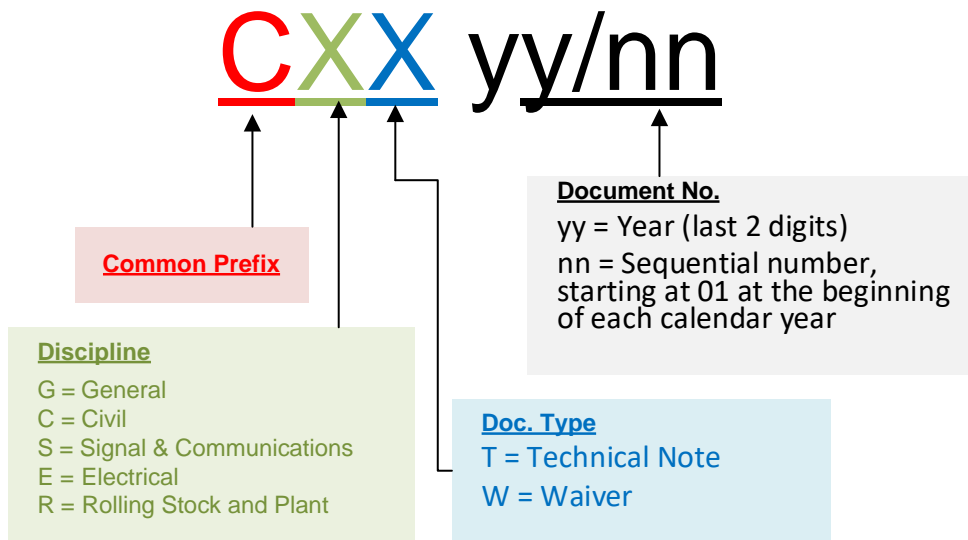

Document numbering convention for Technical Notes and Waivers

Table 2: Document numbering system

Document Type	Number	Example
Engineering Standard	CRN xS nnn	CRN CS 200

Document Type	Number	Example
Engineering Specification	CRN xP nnn	CRN CP 101
Engineering Manual	CRN xM nnn	CRN CM 321
TOC Manual		
Technical Notes	CxT yy/nn	CCT 11/11
Engineering Waivers	CxW yy/nn	CCW 11/02
Civil TMPs		CRN CS 100

6.4.3 General Standards

The suite of manuals that is applicable to all CRN disciplines include;

CRN GM 001 Standards & Codes System Manual

CRN GM 002 Standards & Codes Development Manual

CRN GM 003 Standards & Codes Scope of Coverage

CRN GM 004 Writing Requirements and Guidelines for Operational Maintenance Standards

CRN GM 006 Engineering Waivers

and any other approved standards with the prefix “CRN GM...”

6.4.4 Civil, Signal, Electrical, Plant and Rolling Stock Standards & Codes

All approved discipline specific standards and codes are listed on the CRN standards website. Hyperlinks to the standards and codes managed by TfNSW on CRN behalf are also provided to enable access to all applicable standards from a single location.

7 Application of Standards & Codes

7.1 Relevant personnel

The requirements of CRN Standards & Codes shall be applied by personnel carrying out activities involving;

- CRN infrastructure design, provision, installation, construction, commissioning, maintenance, decommissioning and disposal;
- Provision, commissioning and maintenance of rolling stock and vehicles or on-track equipment that may operate on CRN tracks;
- Provision, commissioning and maintenance of plant and equipment that may be utilised for the design, fabrication, construction, installation, commissioning, maintenance, disposal or operation of CRN infrastructure assets or associated rolling stock;
- CRN asset management and procurement;
- CRN standards and codes development and management; and
- CRN management and operational decision-making relevant to Standards & Codes.

All such personnel shall hold the required competency certification, licenses and authorities required to carry out the above activities.

7.2 Currency and understanding

All personnel undertaking the activities listed in Section 7.1 shall ensure that the relevant standards documents being utilised are the current approved documents from the CRN standards website and that they are fully aware of the requirements of the standards documents related to the activities they are undertaking.

7.3 Standards & Codes interpretation and precedence

Standards & Codes are developed to cover the scope of engineering activities of the CRN within the normal anticipated range of context situations of those activities on the CRN. Personnel carrying out engineering activities on CRN assets or associated rolling stock are to apply appropriate risk management to the activities, including consideration of whether the context of the activity is within the scope and coverage of the Standards & Codes. Context conditions outside the specific coverage of the Standards & Codes may include local or site conditions, unusual activities, or matters outside the specific coverage of the Standards & Codes called up within CRN GM 003 Standards & Codes Scope of Coverage.

Wherever there are issues associated with the application of Standards & Codes to CRN activities, including potential context situations outside the standards coverage, conflicts or ambiguities in standards provisions, the person responsible for the activity shall refer the matter to the relevant UGLRL Principal Engineer for consideration.

Additionally, where an inconsistency is found between a specified CRN standard and an applicable Australian or an International Standard, advice shall be sought from the relevant Principal Engineer as to how the inconsistency should be resolved.

7.4 Standards & Codes development and management

The UGLRL Asset & Engineering Manager holds overall accountability for CRN standards management processes and has delegated authority for approval of General Standards (including this document), for authorisation of approved standards, and for classifying the individual standards under the architecture for the assignment of ownership.

UGLRL Principal Engineers are appointed to cover the engineering disciplines of Civil (track, structures, right of way, geotechnical), Signal & Communications (signal, communications, control systems), Electrical, and Rolling Stock and Plant. Each appointed Principal Engineer has delegated authority and accountability for CRN Standards & Codes development and management within their relevant discipline.

The Principal Engineers report to the Asset & Engineering Manager. The Asset & Engineering Manager, together with the Principal Engineers and representatives from other stakeholder groups form a Standards Technical Committee to cover the development and management of the Standards & Codes.

The processes of Standards & Codes development and management, including the charter of the Standards Technical Committee are covered in CRN GM 002 Standards & Codes Development Manual.

7.5 Competency Requirements

As the accredited rail transport operator for the CRN, it is UGLRL's responsibility to ensure so far as is reasonably practicable that any individual who is carrying out rail safety work on the CRN has the requisite competence and an appropriate level of understanding of CRN Standards & Codes to apply when carrying out that work.

Specific competency requirements are identified within the Standards & Codes documents of each relevant discipline for personnel undertaking the activities listed in Section 7.1 above, as shown in Table 3 below. The management of UGLRL Rail Safety Worker Competence is described in CRN-PRC-RLS-459032646-235 - Training and Competency Procedure. .

For UGLRL internal resources, competency records will be maintained through a combination of internal information systems and the Rail Industry Worker (RIW) System. Competency requirements related to the assignment of engineering authority to individuals working within UGLRL is defined in the O&M Services TCARP.

UGLRL require all contractor and sub-contractor organisations (service providers) to provide evidence of worker's competencies prior to commencement of work by the individual on the CRN. For Rail Safety Workers (RSW), all contractor and sub-contractor organisations are required to register on the RIW System and upload evidence of the competencies of individual workers against the competency requirements for all assigned job roles to be performed on the CRN.

UGLRL will engage with the service providers to ensure that either:

- The service provider has a competency management system in place that meets UGLRL defined principles, or
- the UGL competency management processes are tailored as appropriate and applied to the service provider's employees.

Where the service provider is an Authorised Engineering Organisation (AEO), UGLRL may rely on the authorised competency management processes, with the level of assurance to be determined based on the safety criticality of the work being conducted.

Table 3: Competency definitions in Standards & Codes

Discipline (s)	Relevant Standards & Codes Document for Competency Requirements
Standards development and management, including technical management	CRN GM 002 Standards & Codes Development Manual
Civil (including track, structures, right of way, geotechnical)	CRN CM 001 – Civil Technical Competencies and Engineering Authority
Signal, Communications and Control Systems	CRN ST 001 - Reassessment of Signalling Infrastructure Workers CRN ST 002 - Assessment of Signalling Infrastructure Workers – Licence to Practice
Rolling Stock	Competency requirements are covered by the accreditation requirements of the relevant operator, including the UGLRL Plant Manager for internal UGLRL on-track plant
Electrical	Competency requirements are covered by the licensing of supply authorities

UGLRL is committed to the use of National Competency Standards. In cases where no appropriate national unit of competency exists, or where the national unit of competency does not adequately reflect the skills required for a CRN activity, specific competency definitions may be developed.

The Principal Engineers authorise the use of specific National Competency Standards to conduct the activities defined within the CRN Standards & Codes. Where it is determined that National Competency standards do not adequately reflect the skill set required for an activity, the Principal Engineers may authorise the use of a UGLRL defined Competency Standard. In doing so, they make a determination that a person who has the specific competency will be able to do the work to the desired level of proficiency.

Principal Engineers shall oversight the acceptance of competency requirements through the recruitment or engagement of relevant personnel.

7.6 Engineering licensing and authority

Over and above the requirements for competency, certain critical engineering activities require specific licensing of personnel. These requirements are referenced within the following relevant discipline specific Standards & Codes as follows:

Table 4: Licensing definitions by discipline

Discipline (s)	Relevant Standards & Codes Document for Engineering Licensing
Civil (including track, structures, right of way, geotechnical)	CRN CM 001 – Civil Technical Competencies and Engineering Authority
Signal	CRN ST 002 - Assessment of Signalling Infrastructure Workers – Licence to Practice

The system of licensing, including maintenance of records, is managed within each discipline by the relevant Principal Engineer.

All engineering decision-making activities on the CRN that may affect the safety risk profile of infrastructure or operations shall be carried out by a person with appropriate engineering authority.

These decision-making activities include;

- engineering design of infrastructure;
- inspection and testing of infrastructure;
- certification of infrastructure, including commissioning certification;
- configuration change design and approvals, including variation of operating requirements or restrictions; and
- changes, concessions, and waivers to Standards & Codes.

Engineering authority is delegated from the UGL Board to the UGLRL Chief Executive Officer and then to individuals working within UGLRL, overseen by the UGL Chief Engineer – Projects. This delegation process and outcomes is defined in UGLRL internal document CRN-PLN-AMS-713026361-180 O&M Services Technical Competency, Authority and Review Plan (O&M Services TCARP). This Plan forms part of a set of UGLRL Plans and supporting processes related to the management of competency and authority, which are identified and described in Table 5.

Table 5: UGLRL Competency and Authority Documents

Ref	Document Title	Scope
1	UGLMS-131-470 – Manage Technical Competency & Authority	<p>UGL Management System outlining the UGL competency management and assessment process for roles associated with:</p> <ul style="list-style-type: none"> • Engineering & Design • General Management, Project Management, Rail Safety, HSE, Quality • Construction Management • Maintenance <p>Includes the use of UGLMS-4-2019 Competency Assessment Kit for conducting assessments of the technical competence of employees and Independent Contractors providing engineering services including those related to rolling stock and electrical.</p>
2	CRN-PLN-AMS-713026361-180 – O&M Services Technical Competency, Authority and Review Plan	<p>UGLRL document capturing the application of Ref [1], including:</p> <ul style="list-style-type: none"> • Specific delegation of Authority to UGLRL roles • Specific assignment of personnel to UGLRL roles (with associated authorities) • Specific nomination of competency assessments • Specific nomination and reporting of status of Supplier's competency assessments <p>Outlines the record keeping method(s) for the above roles. Captures the assignment of personnel to roles nominated in Ref [3] below.</p>
3	CRN-PRC-RLS-459032646-240 – CRN Network Management – Operational Authority Process	<p>Nominates the management and authorisation of Network Rules and Procedures and associated Train Control activities required to operate and maintain the Country Regional Network in NSW and the ACT.</p> <p>Specific assignment of personnel to roles is captured in Ref [2] above.</p>
4	CRN-GM-001 –Standards & Codes System Manual	CRN document covering the discipline specific competency requirements for roles on the CRN, including Signalling, Civil, Rolling Stock and Electrical, and other general engineering standards competency requirements.
5	CRN-CM-001 – Civil Technical Competencies & Engineering Authority	CRN document covering civil (track, structures, facilities) activities for maintenance, renewal, construction, and design.
6	CRN-ST-002 – Signalling and Control Systems Personnel – Process for Authorisations and Licensing.	CRN document covering signal licences for signal engineers, signal electricians, signal mechanical, as well as Authorisation for Signal Design.
7	CRN-MPN-RLS-459032646-234 – Training and Competency Management Plan	<p>UGLRL document providing an overview of how overall Rail Safety Worker competency obligations are met, including identification of Rail Safety Workers.</p> <p>Outlines the interaction with the RIW system.</p> <p>Outlines the UGLRL record keeping method(s) for managing in-field competencies including maintenance, renewal, construction, and testing nominated in Ref [5] and [6] above.</p>

Accompanying notes to Table 5:

- (a) Ref [2], [5], and [6] nominate competency requirements for engineering and design activities. Ref [2] nominates UGL requirements for engineering skills and competencies, while Ref [5] and [6] nominate detailed competencies related to the disciplines of civil engineering and signalling engineering respectively, based on existing CRN practices. UGLRL personnel may be required to demonstrate competencies against a combination of these References.
- (b) Ref [2] is the head document related to the delegation of technical Authority within UGLRL and associated competency and shall override any unintended conflicting statements or requirements nominated in Ref [5] or [6].
- (c) Competency records for Ref [5] are to be maintained as nominated in Ref [7] for Maintenance and Construction Level 1, 2 & 3 roles. Competency records for Ref [6] are to be maintained as nominated in Ref [7] for Signal Electrician, Signals Mechanical, and Signals Authorised Persons roles.
- (d) Competency records for Ref [5] are to be maintained as nominated in Ref [2] for Maintenance and Construction Level 4 & 5 roles, as well as Design Level 4 & 5 roles. Competency records for Ref [6] are to be maintained as nominated in Ref [2] for Signal Engineer (Field), and Signals Design roles.

Roles associated with UGLRL Design and Construct Projects – particularly those involving Enhancement Works – should be identified in a Project level TCARP. The Asset and Engineering Manager shall use their judgement (supported by application of UGLMS-131-469 Judgement of Significance (JoS)) to determine if a Project specific TCARP is required for specific Major Periodic Maintenance activities.

The delegation of engineering authority is only to individuals and is subject to the individual holding the required competency and / or licensing requirements. The authority to further delegate shall be specified within each delegated authority.

7.7 Verification, validation, certification and / or approval

All changes to CRN assets or rolling stock which may affect the safety of CRN assets or operations shall be subject to verification during both design and implementation of the changes. Specific requirements for verification are set out in UGLRL discipline standards and in the following:

CRN-POL-AMS-713026361-114 - Asset Management Policy

CRN-MPN-RLS-713026361-103 - Asset Management Framework

CRN-PLN-AMS-713026361-304 - Configuration Management Plan

CRN-PLN-AMS-1737869751-32 - Terms of Reference - Configuration Control Board

Where changes to the use or operation of CRN assets or rolling stock may affect the safety of CRN assets or operations, the changes shall be subject to validation of the changes. Specific requirements for validation are set out in UGLRL discipline standards and in CRN-PRC-RLS-459032646-177 - Management of Change Procedure.

All proposed changes subject to verification or validation shall be certified and approved for implementation by persons with appropriate engineering authority.

7.8 Compliance and audit

The Operational Maintenance Standards include requirements for extensive processes of inspection and testing for assurance of compliance of CRN assets to Standards & Codes. The UGLRL Infrastructure Maintenance Manager is responsible for implementing these processes.

In addition to these processes a separate compliance function is established to audit compliance on a sampling basis. Refer to CRN-MPN-QMS-823503868-10 Quality Assurance Management Plan

7.9 Management of non-compliance

Management processes shall be established to manage potential and actual non-compliance of assets to Standards and Codes. These processes include:

- Defects Management System
- Risk based processes for granting permanent standards exemptions or concessions
- Risk based processes for granting operational maintenance standards waivers for defined time periods

7.10 Change management

UGLRL is required to have in place procedures for ensuring changes which may affect the safety of rail operations are identified and managed.

Relevant to this requirement include changes to:

- assets due to infrastructure maintenance or works activities
- engineering standards
- Rolling stock
- Operating requirements, including the requirements of the TOC Manual

Where there is a potential for change to affect the safety of rail operations, the change is to be managed in accordance with the CRN-PRC-RLS-459032646-177 - Management of Change Procedure.

7.11 Application of risk management to engineering standards

Personnel carrying out engineering activities on UGLRL assets or associated rolling stock shall apply appropriate risk management to the activities in accordance with the requirements of the CRN Safety Management System Document HSE Risk Management Procedure CRN-PRC-RLS-459032646-180. The requirements for risk management are addressed through the Standards & Codes in the following ways:

- The Standards & Codes provide controls to specific hazards or risk contributory factors identified in the UGLRL Risk Register. The required Standards & Codes functional areas for application of these controls are identified in the UGLRL Risk Register. The Principal Engineers are responsible for assuring the detailed implementation of these controls within the provisions of the engineering standards.
- The processes for development and management of the Standards & Codes include risk assessment of changes to engineering standards. The requirements for this are set out in CRN GM 002 Standards & Codes Development Manual.
- The Standards & Codes specify particular risk processes for engineering activities carried out on CRN assets and the associated rolling stock.
- The engineering and standards functions of UGLRL management is a contributory stakeholder in the management of the CRN risk profile. Principal Engineers provide risk controls which are identified in the UGLRL Risk Register for engineering activities.

7.12 Concessions and waivers

Where personnel carrying out engineering activities consider that the provisions of the Standards & Codes are not appropriate or too stringent for the particular activity to be undertaken, they may refer the matter to the appropriate Principal Engineer. If the derogation request relates to an engineering standard or code managed by TfNSW, the Principal Engineer may advise to request a concession from TfNSW.

The Principal Engineer may grant a waiver to an operational maintenance standard. Waivers may be either permanent variations to the requirements of the operational maintenance standards or temporary variations to apply for a specified time period. Waivers must meet the requirements specified in CRN GM 006 “Engineering Waivers”.

Permanent waivers are only applied to particular instances of the engineering activity or to particular assets and not generally across the CRN. If permanent waivers are requested for general application across the CRN, they are to be managed as proposed operational maintenance standards changes, in which case a temporary waiver may be issued until the standards changes are published.

7.13 Communications

The Principal Engineers shall establish processes for communication of and consultation on Standards & Codes matters with internal and external Standards & Codes stakeholders.

These processes may include briefings of relevant personnel on Standards & Codes changes and updates on relevant industry information and experience.

7.14 Records of Standards & Codes application

The following records of Standards & Codes application shall be maintained within the UGLRL documentation or asset management systems:

- Competencies of personnel
- Delegation of engineering authorities
- Configuration change and design documentation, including works as executed drawings
- Certification activities, including verification, validation, approval and authorisation, covering standards changes, design, configuration change, asset and rolling stock certification
- Granting of concessions and waivers
- Defects and non-compliance, including records of rectification
- Changes to standards & codes
- Risk assessments
- Audits

8 Standards & Codes interfaces

Standards & Codes provide support to and contain requirements for many functional areas of UGLRL. This section of the Standards & Codes System Manual contains guidance on the interfaces between the Standards & Codes and key functional activities of UGLRL.

8.1 CRN infrastructure asset management

For managers undertaking asset management activities:

- the Standards & Codes provide;
 - specific standards and codes to which the assets are to comply and against which non-compliance and defects can be identified; and
 - baseline standards and codes requirements, against which the performance of assets can be assessed
- and the managers shall;
 - incorporate standards and codes requirement into the overall asset management system; and

- prepare annual works plans for the short term and long term assurance of compliance.

8.2 Infrastructure maintenance, works and infrastructure operations

For maintenance managers and managers of works on the CRN assets, including managers of third party works:

- the Standards & Codes provide;
 - specific engineering requirements for the works.
- and the managers shall;
 - assure that assets comply with the requirements of the Standards & Codes.

8.3 Network, train and on-track equipment operations

For operating managers of the CRN Network and operating managers of trains and on-track equipment on CRN tracks:

- the Standards & Codes provide;
 - The Train Operating Conditions (TOC) manual; and
 - Rolling stock standards.
- and the managers shall;
 - operate the CRN networks and trains within the requirements of the TOC Manual; and
 - assure that rolling stock and on-track equipment operating on CRN tracks complies with the rolling stock standards.

8.4 Safety and environmental management

For managers of the safety and environment function of UGLRL:

- the Standards & Codes provide;
 - assurance of Standards & Codes support to the requirements of rail safety accreditation through compliance to the Safety Management System;
 - controls for rail safety risks identified in the UGLRL Risk Register; and
 - Engineering controls to particular hazards and risk contributory factors to enable UGLRL railway operations to be carried out safely.
- and the managers shall;
 - manage the stakeholder interface with Standards & Codes by communicating changes in accordance with CRN-PRC-RLS-459032646-211 - Communication and Consultation Procedure and CRN-PRC-RLS-459032646-177 - Management of Change Procedure

8.5 Human resources and training

For managers of the human resources and training function of UGLRL:

- the Standards & Codes provide;
 - competency requirements for personnel undertaking engineering activities;
 - a frameworks for licensing and authorising personnel to undertake engineering activities; and
 - training manuals and requirements.
- and the managers shall;

- establish and maintain processes to assure recruited and or appointed personnel have the required competencies;
- establish and maintain personnel records management, including personnel registers of competencies, engineering licences and authorities; and
- manage training of infrastructure and asset management personnel in the application of the standards and codes.
- establish and maintain processes to assess the continuing competencies of personnel.

9 Standards & Codes improvement framework

9.1 Standards & Codes review and change

The CRN Standards & Codes are subject to review and change as part of the processes of asset management and continuous improvement. CRN-PRC-RLS-459032646-177 - Management of Change Procedure and CRN-E-P004 Changes to Engineering Standards describes the change processes applicable to Engineering Standards & Codes and to Operational Maintenance Standards. Changes to standards & codes may be instigated by a number of factors including:

- changes in the business or operations of the CRN
- changes to the CRN extent or physical configuration
- changes to CRN business and operational configurations, including changes to the UGLRL Safety Management System, management structure or business and operational systems
- developing experience in the application of Standards & Codes to CRN assets and operations
- identified areas of asset or operational performance that could be improved by change to the standards and codes
- improved engineering controls in the management of risk
- changes in the regulatory framework under which the CRN operates
- changes in technology
- external changes, including changes to standards of interfacing organisations and wider industry standards
- developments in rail industry knowledge and experience

All users of CRN Standards & Codes have an obligation to identify and report on issues which may arise in the application of standards and codes and to make suggestions for improvements to standards and codes.

9.2 Identifying Standards & Codes issues and opportunities for improvement

The processes for identifying and reporting on standards issues and making suggestions for improvements are described in Standards & Codes Development Manual CRN-GM-002.